

Technical Data Sheet

Opto Interrupter SGM9803

■ Features

- Fast response time
- High analytic
- Peak wavelength $\lambda_p=940\text{nm}$
- High sensitivity
- Pb free

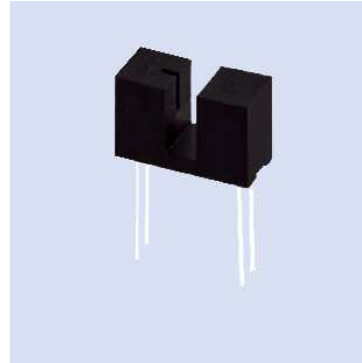

■ Descriptions

The SGM9803 consist of an infrared emitting diode and an NPN silicon phototransistor, encased side-by-side on converging optical axis in a black thermoplastic housing . The phototransistor receives radiation from the IR LED only. This is the normal situation. But when an object is in between , phototransistor could not receives the radiation.

■ Applications

- Non-contact Switching
- Switch Scanner
- For Direct Board
- Floppy disk driver

■ **Package Dimensions**

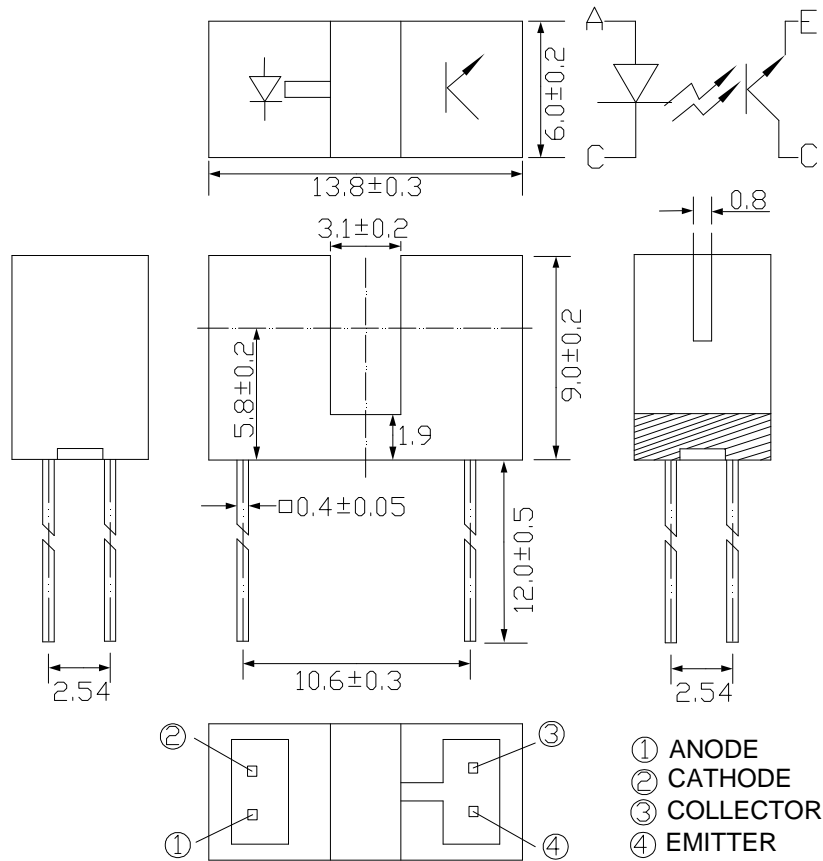

Note: 1. All dimensions are in millimeters
 2. Tolerances unless dimensions ± 0.3 mm

■ **Absolute Maximum Ratings (Ta=25°C)**

Parameter		Symbol	Rating	Units
Input	Power Dissipation at(or below) 25°C Free Air Temperature	Pd	75	mW
	Reverse Voltage	VR	5	V
	Continuous Forward Current	IF	50	mA
	Peak Forward Current (*1)	IFP	0.5	A
Output	Collector Power Dissipation	Pd	75	mW
	Collector Current	Ic	20	mA
	Collector-Emitter Voltage	VCEO	30	V
	Emitter-Collector-Voltage	VECO	5	V
Lead Soldering Temperature (*2)		Tsol	260	°C
Operating Temperature		Topr	-25 ~ +85	°C
Storage Temperature		Tstg	-40 ~ +85	°C

Notes: *1:IFP Conditions--Pulse Width $\leq 100 \mu s$ and Duty $\leq 1\%$.

*2:Soldering time ≤ 5 seconds.

■ **Electro-Optical Characteristics (Ta=25°C)**

Parameter		Symbol	Min.	Typ.	Max.	Units	Conditions
Input	Forward Voltage	V _F	--	1.2	1.5	V	I _F =20mA
	Reverse Current	I _R	--	--	10	μA	V _R =5V
	Peak Wavelength	λ _p	--	940	--	nm	I _F =20mA
	View Angle	2θ 1/2	--	60	--	Deg	I _F =20mA
Output	Dark Current	I _{CEO}	--	--	100	nA	V _{CE} =20V, E _e =0mw/cm ²
	C-E Saturation Voltage	V _{CE (S)}	-	--	0.4	V	I _c =2mA, E _e =1mw/cm ²
Transfer Characteristics	Collector Current	I _{C (ON)}	0.5	--	10	mA	V _{CE} =5V, I _F =20mA
		I _{C (OFF)}	--	--	20	μA	
	Rise Time	t _r	--	15		μS	V _{CE} =5V, I _C =1mA
	Fall Time	t _f	--	15		μS	R _L =1000

■ **Typical Electro-Optical Characteristics Curves for IR**

Fig.1 Forward Current vs. Ambient Temperature

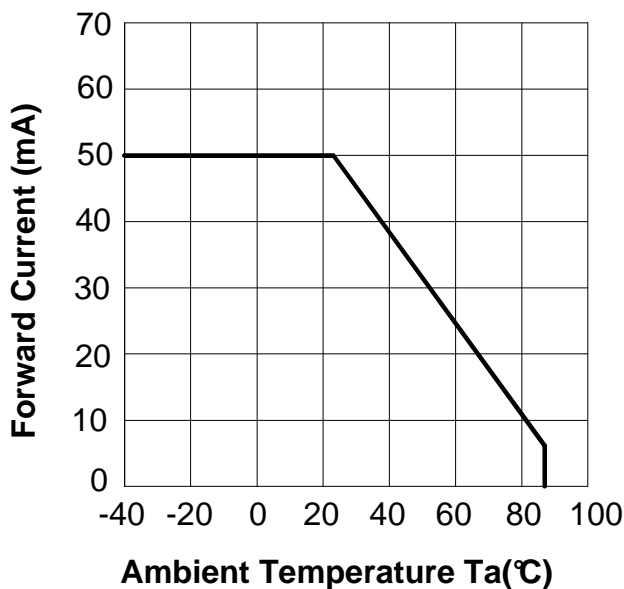

Fig.2 Spectral Distribution

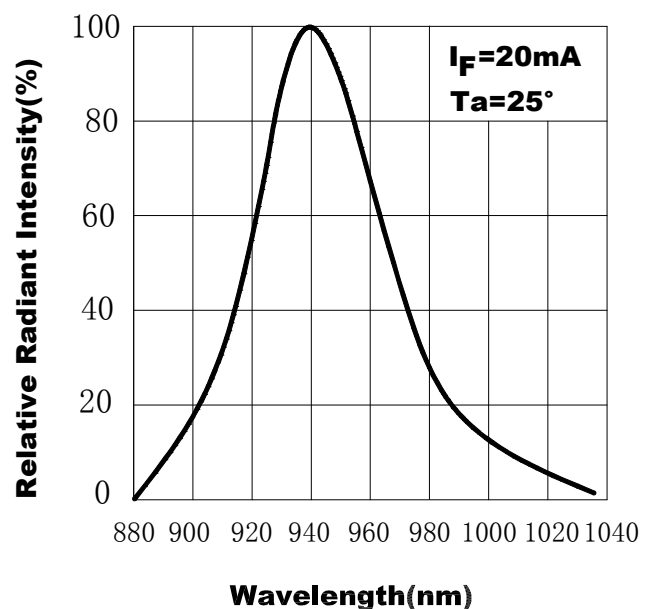

Fig.3 Peak Emission Wavelength vs. Ambient Temperature

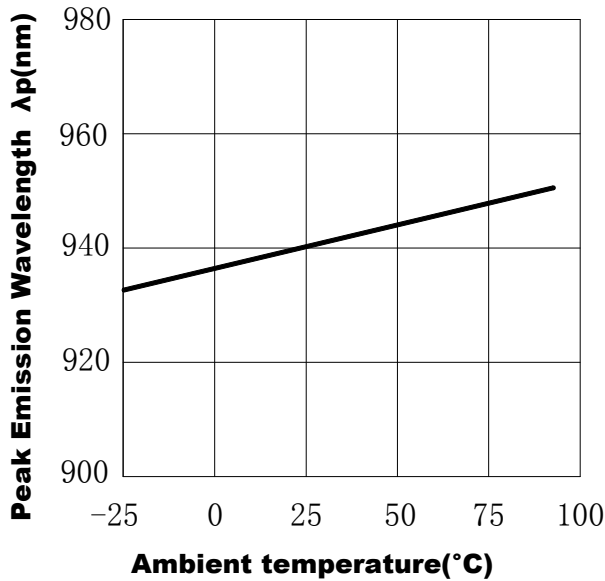

Fig.4 Forward Current vs. Forward Voltage

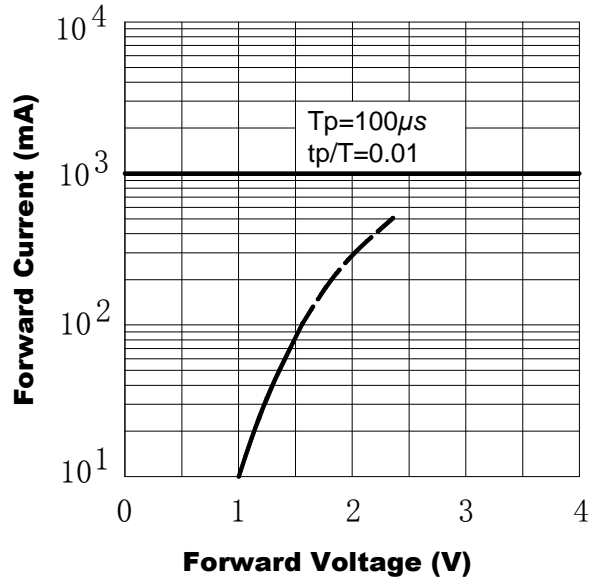

Fig.5 Radiant Intensity vs. Forward Current

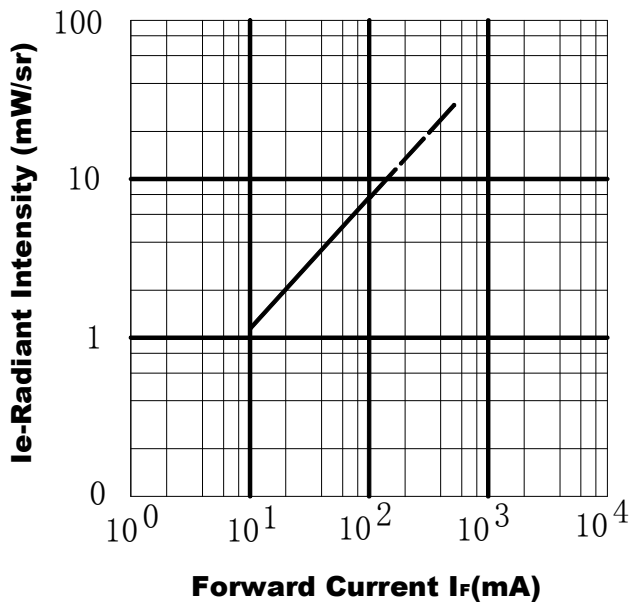
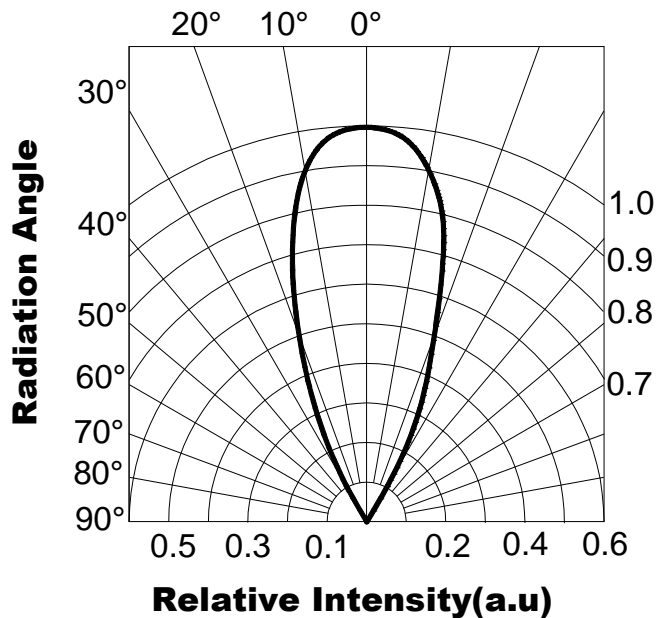

Fig.6 Relative Radiant Intensity vs. Angular Displacement



■ Typical Electro-Optical Characteristics Curves for PT

Fig.1 Collector Power Dissipation vs. Ambient Temperature

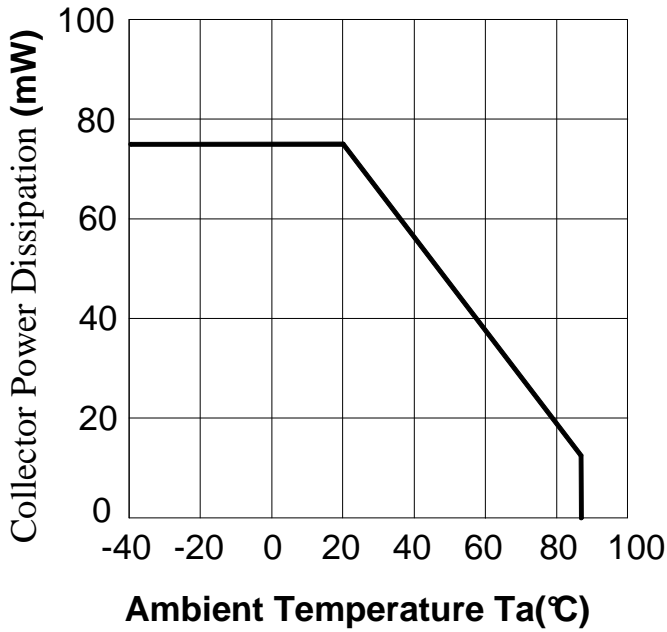

Fig.2 Spectral Sensitivity

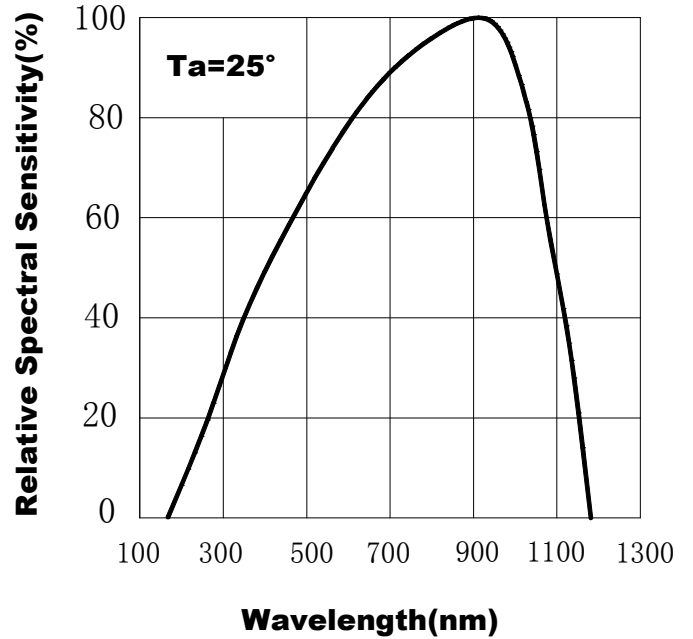

Fig.3 Relative Collector Current vs. Ambient Temperature

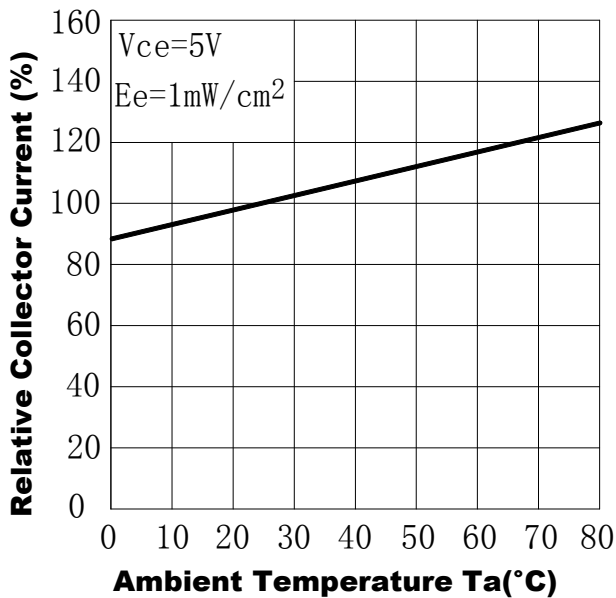

Fig.4 Collector Current vs. Irradiance

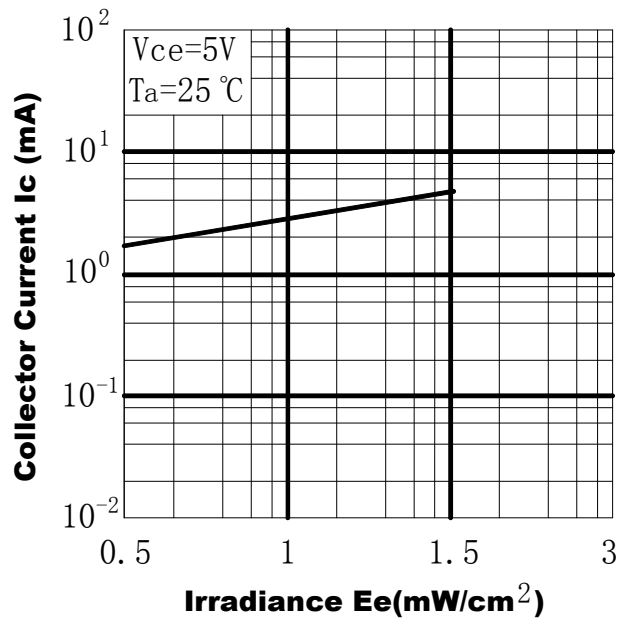

Fig.5 Collector Dark Current vs.
Ambient Temperature

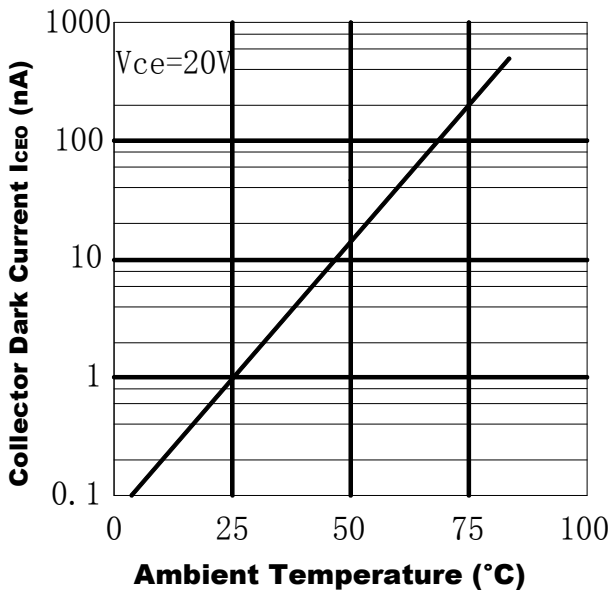
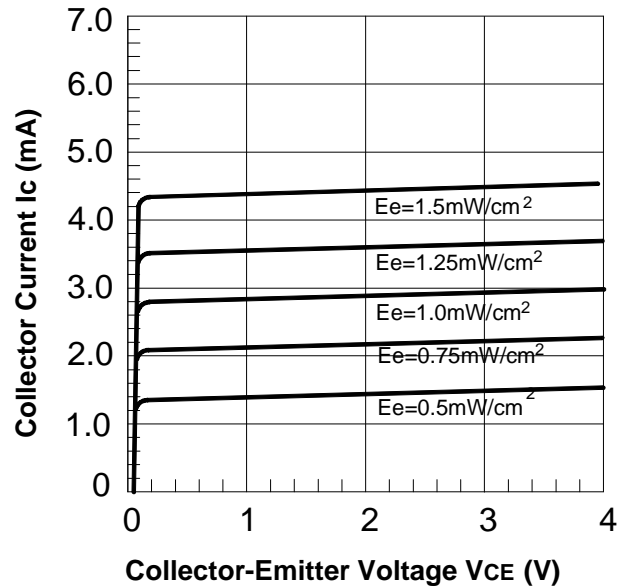

Fig.6 Collector Current vs.
Collector-Emitter Voltage



■ Packing Quantity Specification

1. 100PCS/1Bag

■ Notes

1. Above specification may be changed without notice. SHUGUAN will reserve authority on material change for above specification.
2. When using this product, please observe the absolute maximum ratings and the instructions for using outlined in these specification sheets. SHUGUAN assumes no responsibility for any damage resulting from use of the product which does not comply with the absolute maximum ratings and the instructions included in these specification sheets.
3. These specification sheets include materials protected under copyright of SHUGUAN corporation. Please don't reproduce or cause anyone to reproduce them without SHUGUAN's consent.