

## Technical Data Sheet

### Infrared Remote control Receiver Module

SGR6538L

#### ■ Features

- Photo detector and preamplifier in one package
- Internal filter for PCM frequency
- TTL and CMOS compatibility
- Low power consumption
- Improved immunity against ambient light
- Suitable burst length  $\geq 10$  cycles/burst
- Long reception distance.
- Pb free
- The product itself will remain within RoHS compliant version.



#### ■ Descriptions

The SGR6538L is miniaturized receivers for infrared remote control systems. PIN diode and preamplifier are assembled on lead frame, the epoxy package is designed as IR filter. The demodulated output signal can directly be decoded by a microprocessor. SGR6538L is the standard IR remote control receiver, supporting all major transmission codes.

#### ■ Applications

- ◆ AV instruments such as Audio, TV, VCR, CD, MD, etc.
- ◆ Home appliances such as Air-conditioner, Fan , etc.
- ◆ Light detecting portion of remote control
- ◆ CATV set top boxes
- ◆ Multi-media Equipment
- ◆ The other equipments with wireless remote control

#### ■ Application Circuit:

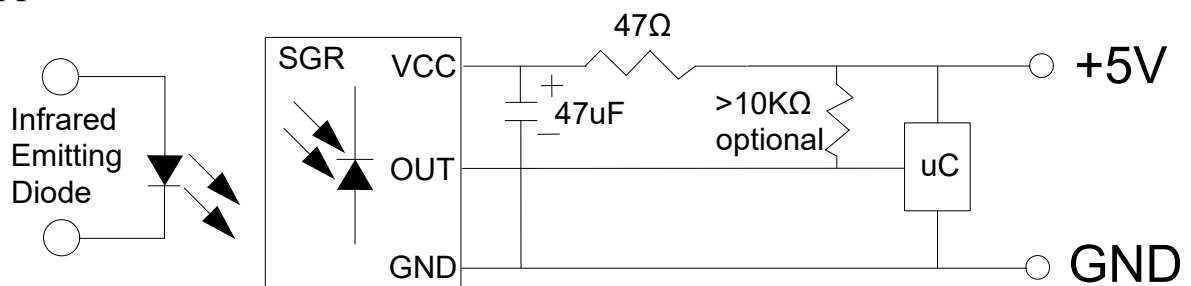

RF Filter should be connected closely between Vcc pin and GND pin.

## SGR6538L Code Property:

Data format		Data format	
NEC	O	Zenith	O
GRUNDIG	O	RCA _ Thomson	X
RC5 _ Philips	O	SHARP	O
RC6 _ Philips	O	SONY 12BIT	O
RCMM	X	SONY 15BIT	X
Matsushita	O	SONY 20BIT	X
Toshiba	O	Mitsubishi	O
RCS-80	O	High data rate(4000 bit/s)	X

Notes: O: Recommended X: Not recommended

### ■ Block Diagram:

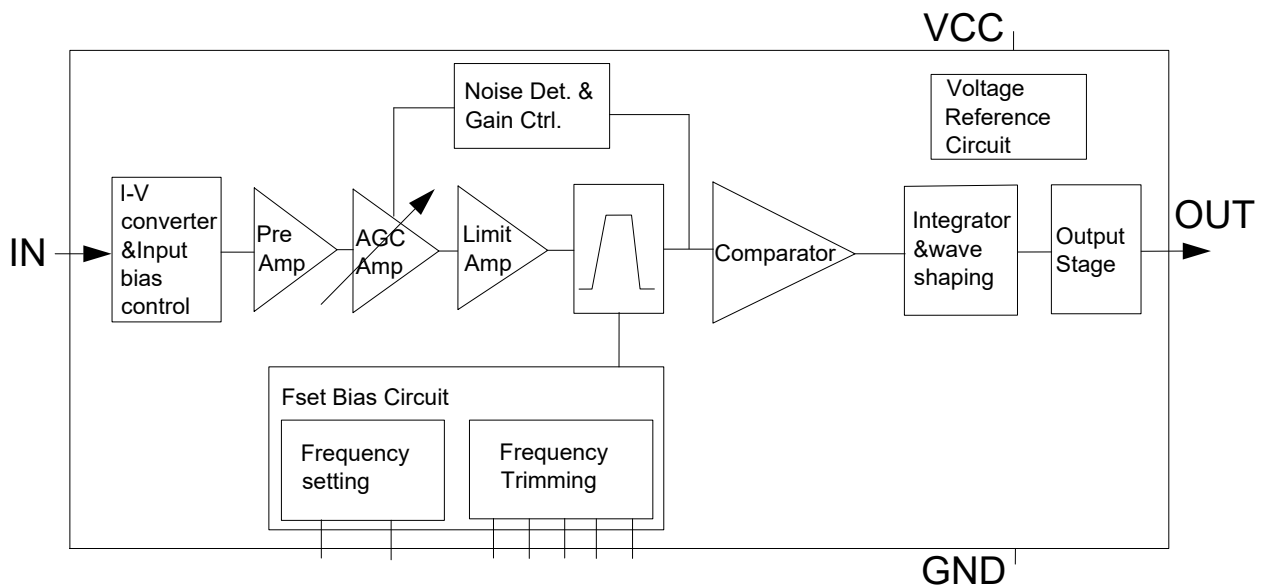

### ■ Absolute Maximum Ratings (Ta=25°C)

Parameter	Symbol	MIN.	MAX.	Unit
Supply Voltage	V <sub>CC</sub>	0	5.5	V
Output Voltage	V <sub>out</sub>	0	5.5	V
Output Current	I <sub>out</sub>	0	2.5	mA
Operating Temperature	T <sub>opr</sub>	-20	80	°C
Storage Temperature	T <sub>st</sub>	-40	125	°C

### ■ Recommended Operating Conditions

Parameter	Symbol	Min.	Typ.	Max.	Unit
Operating Voltage	V <sub>CC</sub>	2.0	3.3	5.5	V
Input Frequency	F <sub>in</sub>	--	37.9	--	kHz
Operating Temperature	T <sub>opr</sub>	-20	25	80	°C

### ■ Electro-Optical Characteristics (T<sub>a</sub>=25°C, and V<sub>cc</sub>=3V/5V)

Parameter	Symbol	Min.	Typ.	Max.	Unit	Conditions
Supply Current	I <sub>CC</sub>	--	50	120	μA	I <sub>in</sub> =0 μA, V <sub>cc</sub> =3V
		-	55	120	μA	I <sub>in</sub> =0 μA, V <sub>cc</sub> =5V
High Level Output Voltage	V <sub>OH</sub>	V <sub>CC</sub> -0.4	V <sub>CC</sub>	--	V	V <sub>cc</sub> =3V, V <sub>cc</sub> =5V
Low Level Output Voltage	V <sub>OL</sub>	--	0.2	0.4	V	I <sub>sink</sub> =2.5mA
Reception Distance	L <sub>0</sub>	10	--	--	m	θ=0°
	L <sub>45</sub>	6	--	--		θ=45°
Half Angle(Horizontal)	θ <sub>h</sub>	-	45	-	deg	
Half Angle(Vertical)	θ <sub>v</sub>	-	45	-	deg	
Peak Wavelength	λ <sub>P</sub>	-	940	-	nm	
High Level Pulse Width	T <sub>1</sub>	480	600	720	μs	F <sub>in</sub> =37.9kHz, 600μs
Low Level Pulse Width	T <sub>2</sub>	480	600	720	μs	F <sub>in</sub> =37.9kHz, 600μs
Center Frequency	f <sub>c</sub>	-	37.9	-	kHz	

### ■ Test Method :

The specified electro-optical characteristics is satisfied under the following Conditions at the controllable distance.

#### ◆ Measurement place:

A place that is nothing of extreme light reflected in the room.

#### ◆ External light:

Project the light of ordinary white fluorescent lamps which are not high Frequency lamps and must be less then 10 Lux at the module surface. (E<sub>e</sub> ≦ 10Lux)

#### ◆ Standard transmitter:

Standard transmitter: A transmitter whose output is so adjusted as to V<sub>o</sub>=400mV<sub>p-p</sub> and the output Wave form shown in Fig.-1. According to the measurement method shown in Fig.-2 the standard transmitter is specified.

However , the infrared photodiode to be used for the transmitter should be λ<sub>p</sub>=940nm, Δλ =50nm. (Standard light / Light source temperature 2856°K).

#### ◆ Measuring system:

According to the measuring system shown in Fig.-3

Fig.-1 Transmitter Wave Form

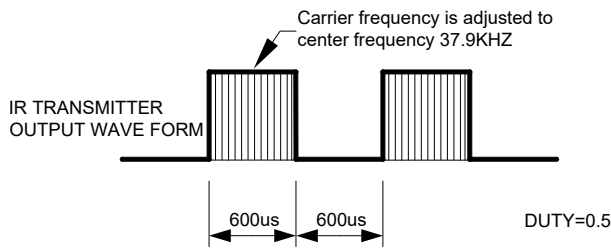

D.U.T output Pulse

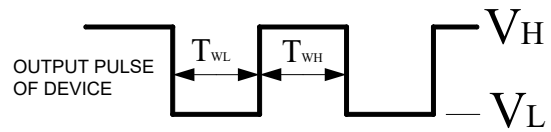

Fig.-2 Measuring Method

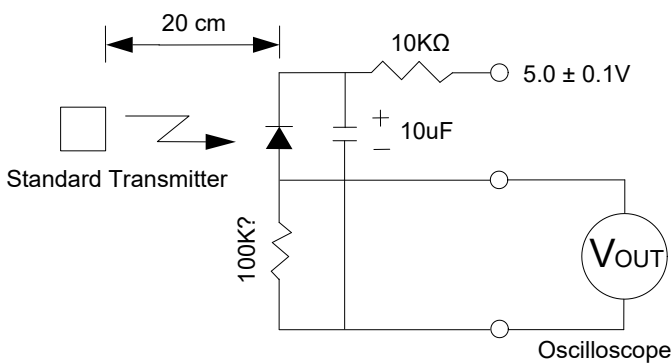
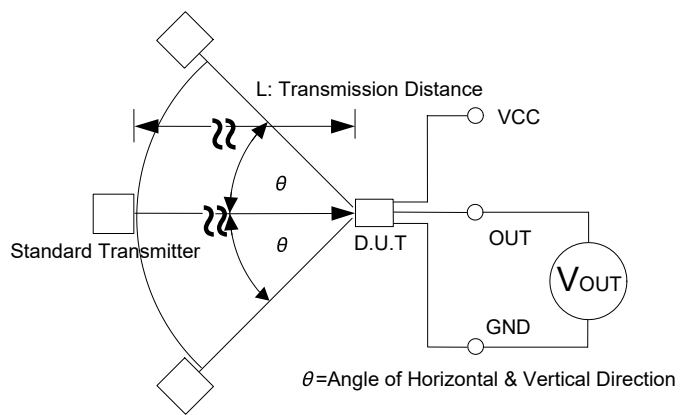

Fig.-3 Measuring System



■ The Notice of Application:

Transmission of remote control signal consist of four parts: Encode Part, IR Transmitter Source, SGR device, Decode Part

1. Strong or weak light of IR Transmitter can affect distance of transmission.
2. When using the SGR6538L, it requires the composition of code pattern to reach the demand as follows:

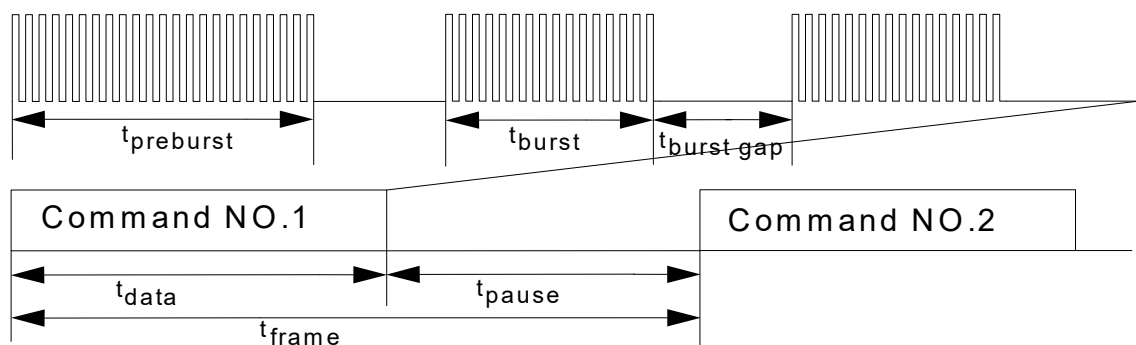

Minimum $t_{burst}$ (number of pulses per burst)	Minimum $t_{burst\_gap}$ (number of pulses between two burst)	Minimum $t_{pause}$
10 pulses	14 pulses	50 msec

3. It needs to ensure the translation range of decode part if it is applied to the pulse-width range. If the above items hardly assure of its application, it'll cause NG(no good) message from the edge of signal.

**■ Package Dimensions**

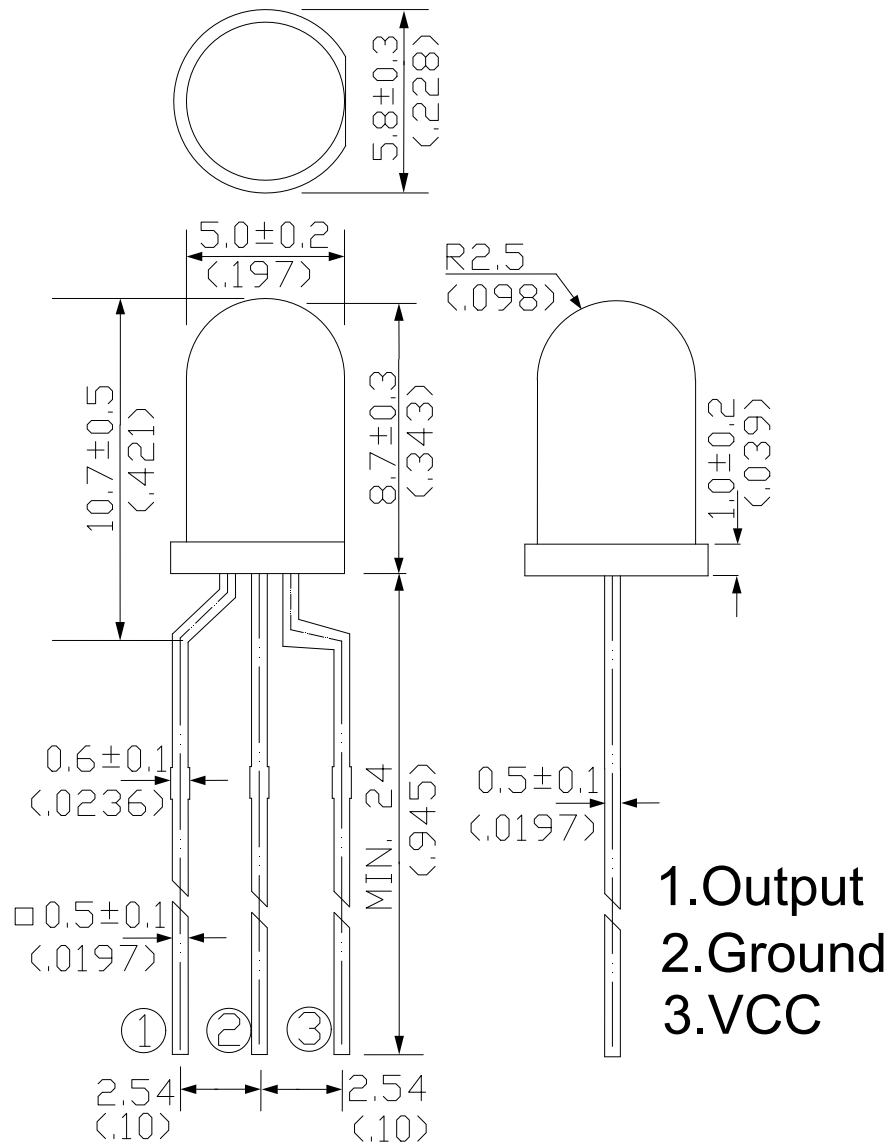

Note: 1. All dimensions are in millimeters(inches)  
 2. Tolerances unless dimensions  $\pm 0.25$ mm(.01")

**■ Packing Quantity Specification**

500 PCS/1 Bag