

Technical Data Sheet

0.8mm Height Flat Top Infrared LED: SIR1921C

■ Features

- Dominant Wavelength 940nm
- Low forward voltage
- Pb free
- Compliance with EU REACH
- The product itself will remain within RoHS compliant version.

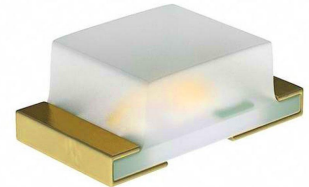

■ Descriptions

The SIR1921C is an infrared emitting diode in miniature SMD package which is molded in a water clear plastic with flat top view lens. The device is spectrally matched silicon photodiode and phototransistor.

■ Applications

- PCB mounted infrared sensor
- Infrared emitting for miniature light barrier
- Optoelectronic switch
- Smoke detector

■ Package Dimensions

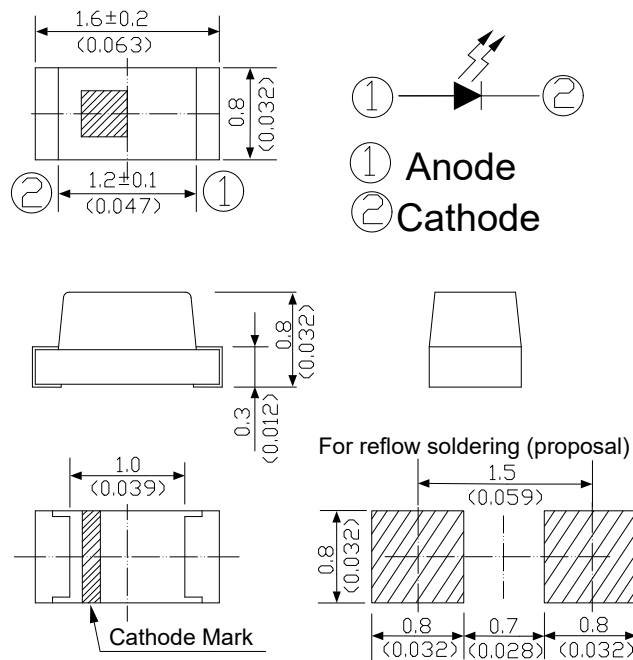

- Note: 1. All dimensions are in millimeters(inches)
 2. Tolerances unless dimensions $\pm 0.1\text{mm}(.004\text{'})$
 3. Suggested pad dimension is just for reference only
 Please modify the pad dimension based on need

■ Absolute Maximum Ratings (Ta=25°C)

Parameter	Symbol	Rating	Units
Continuous Forward Current	I _F	65	mA
Peak Forward Current (Duty 1/10 @ 1KHZ)	I _{PF}	300	mA
Reverse Voltage	V _R	5	V
Power Dissipation	P _d	130	mW
Lead Soldering Temperature	T _{sol}	260	°C
Operating Temperature	T _{opr}	-25 ~ +85	°C
Storage Temperature	T _{stg}	-40 ~ +85	°C

■ Electro-Optical Characteristics (Ta=25°C)

Parameter	Symbol	Condition	Min.	Typ.	Max.	Units
Radiant Intensity	I _e	I _F = 20mA	0.2	0.7	---	mW/sr
Viewing Angle	2θ _{1/2}	I _F = 20mA	---	150	---	deg
Dominant Wavelength	λ _d	I _F = 20mA	---	940	---	nm
Spectrum Radiation Bandwidth	Δλ	I _F = 20mA	---	50	---	nm
Forward Voltage	V _F	I _F = 20mA	---	1.2	1.5	V
Reverse Current	I _R	V _R = 5V	---	---	10	μA

■ Typical Electro-Optical Characteristics Curves

Fig.1 Forward Current vs.

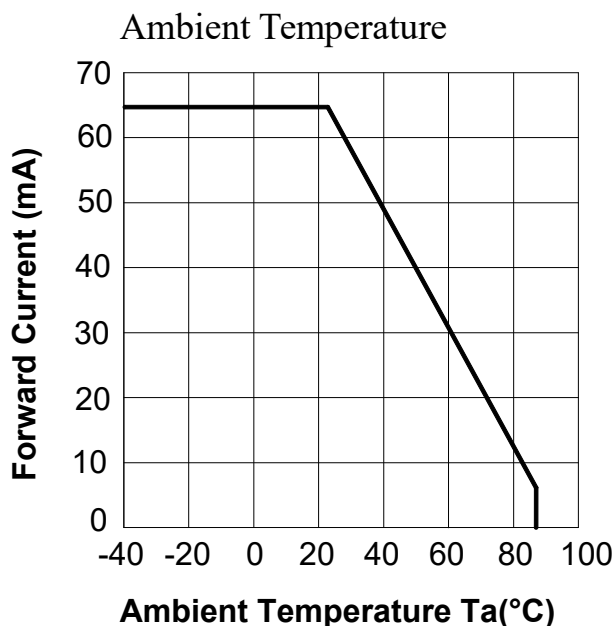

Fig.2 Spectral Distribution

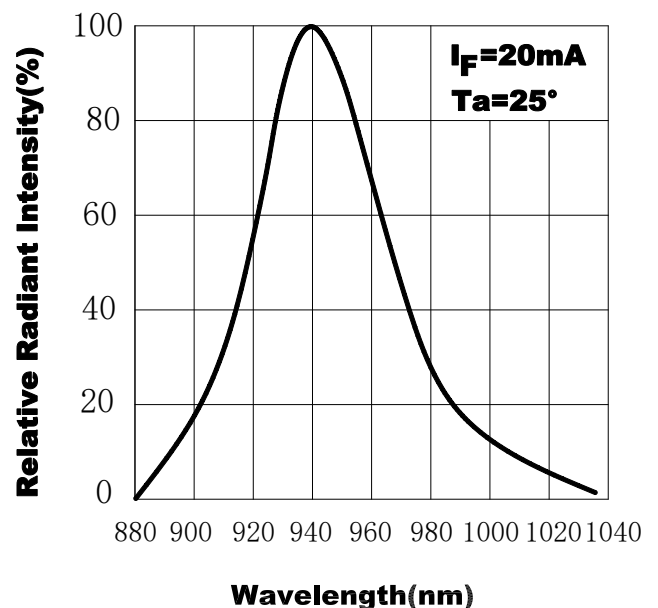

Fig.3 Peak Emission Wavelength vs. Ambient Temperature

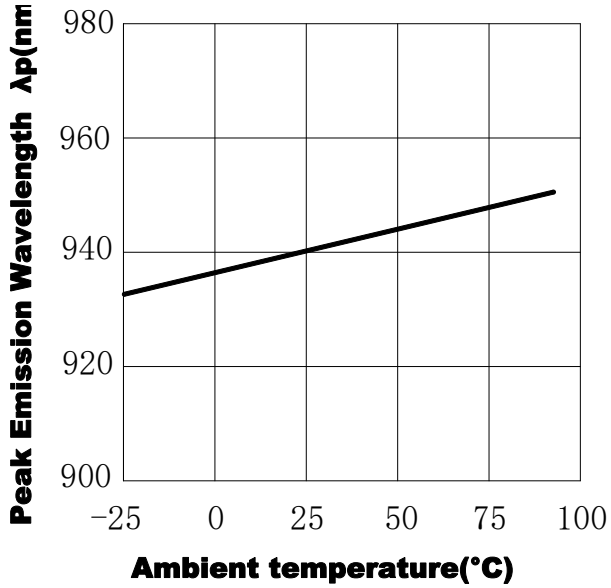

Fig.4 Forward Current vs. Forward Voltage

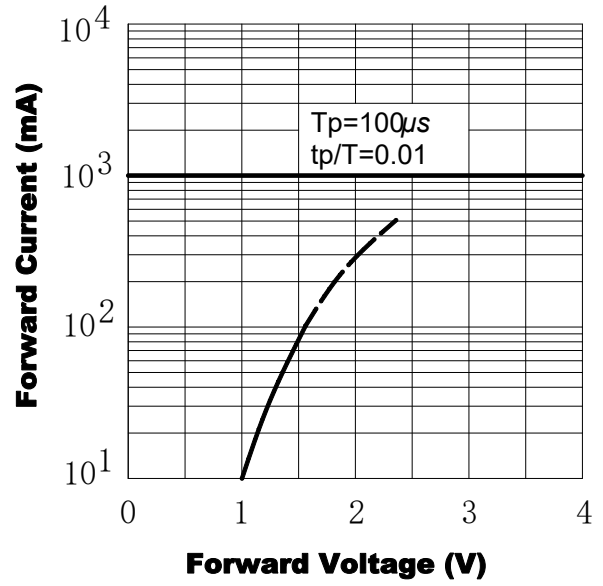

Fig.5 Radiant Intensity vs. Forward Current

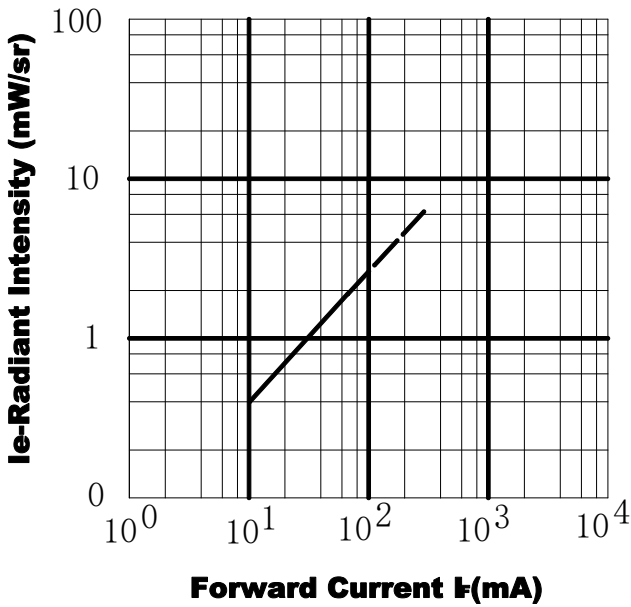

Fig.6 Relative Radiant Intensity vs. Angular Displacement

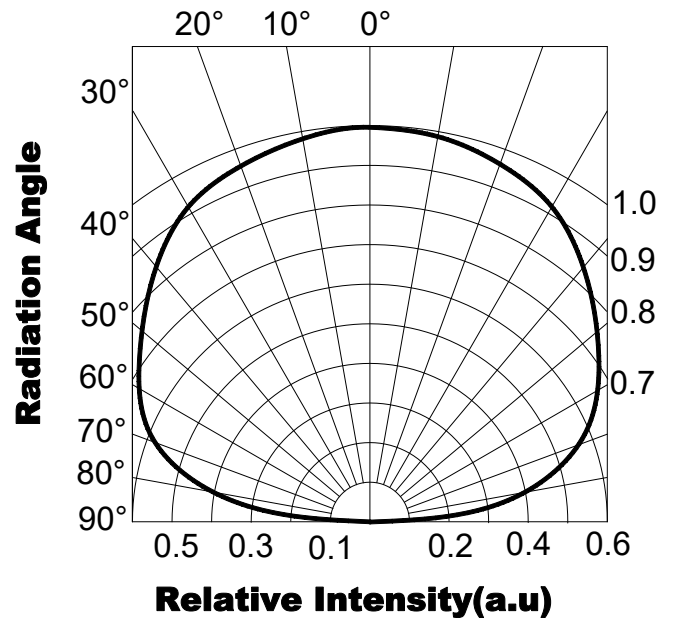

Fig.7 Relative Intensity vs. Ambient Temperature (°C)

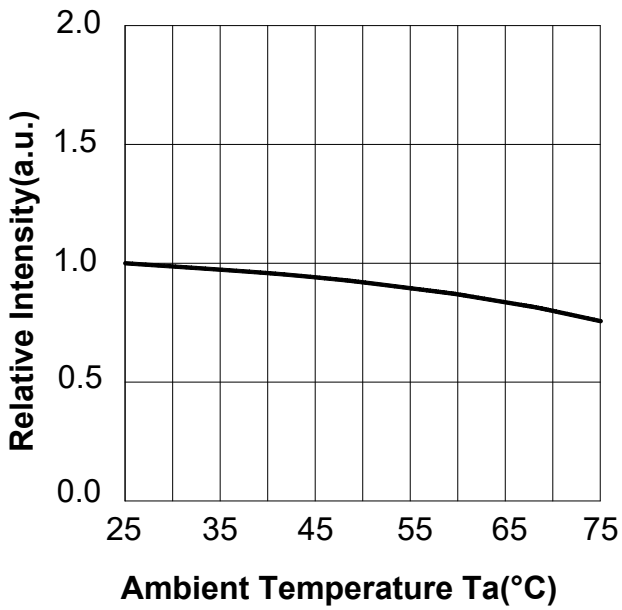
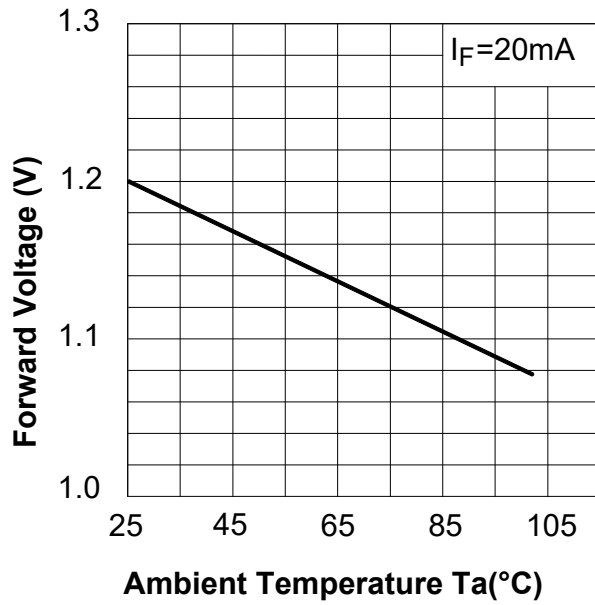
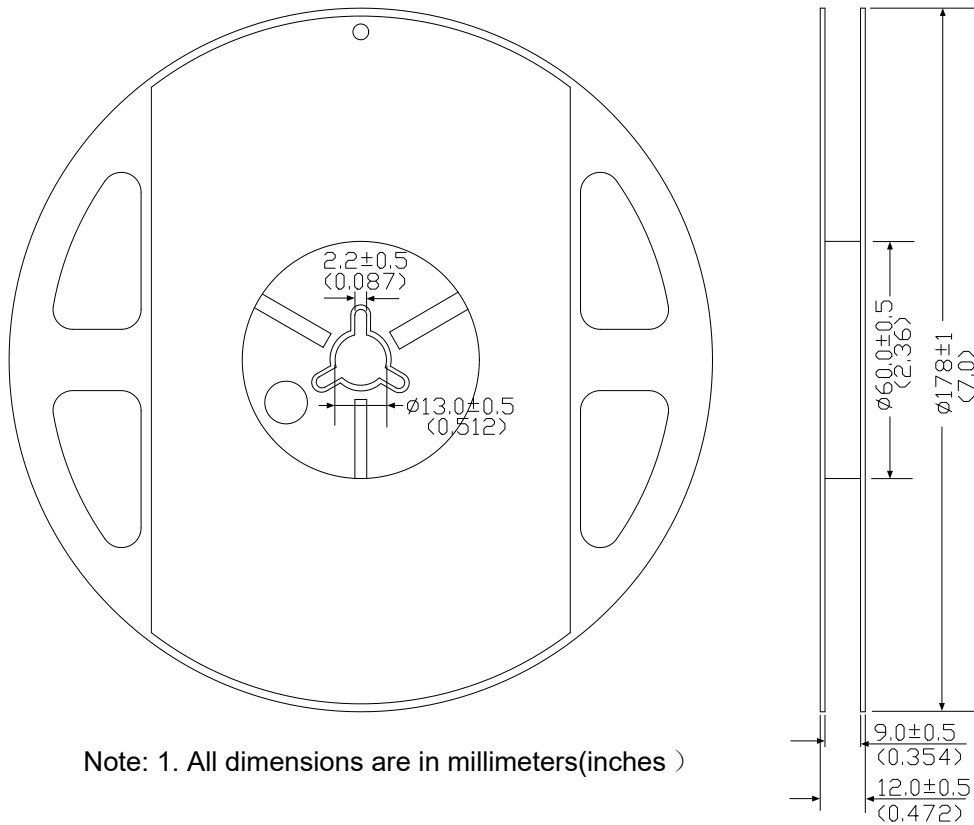

Fig.8 Forward Voltage vs. Ambient Temperature (°C)



■ Packing Dimensions



Note: 1. All dimensions are in millimeters(inches)

Carrier Tape Dimensions (Quantity: 3000 pcs/reel)

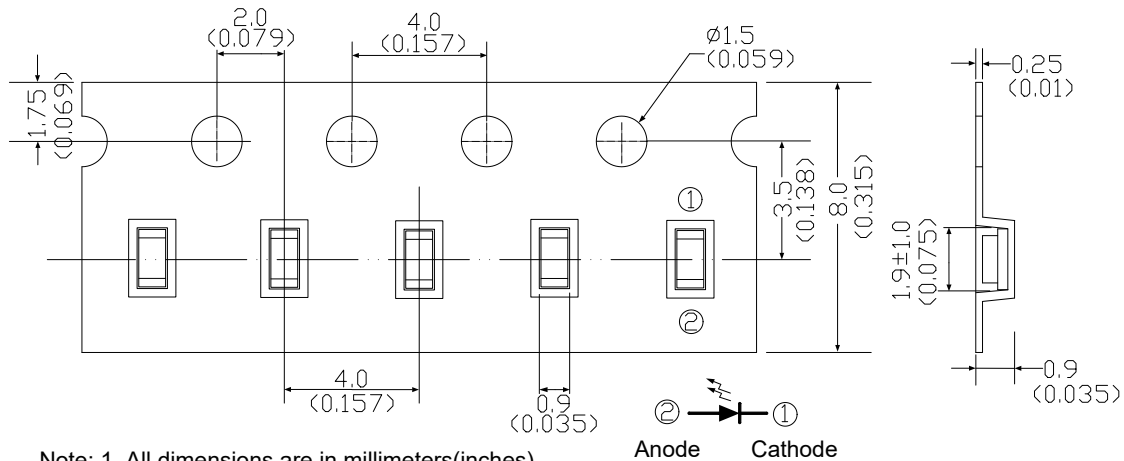

Notes

1. Above specification may be changed without notice. SHUGUAN will reserve authority on material change for above specification.
2. When using this product, please observe the absolute maximum ratings and the instructions for using outlined in these specification sheets. SHUGUAN assumes no responsibility for any damage resulting from use of the product which does not comply with the absolute maximum ratings and the instructions included in these specification sheets.
3. These specification sheets include materials protected under copyright of SHUGUAN corporation. Please don't reproduce or cause anyone to reproduce them without SHUGUAN's consent.